

Fast Large Signal Identification (pre-release)

S75

Module of the KLIPPEL R&D SYSTEM (Document Revision 1.1)

FEATURES

- Measures **small and large signal speaker parameters**
- Identifies the **root causes of distortion**
- Fully **automatic measurement** process
- **Minimal measurement time**: 20 seconds to a few minutes
- Supports electro-dynamic transducers in free air, closed, vented, and passive radiator systems
- Supports tweeters, micro-speakers, sidefire speakers
- Generates accurate **linear and nonlinear parameters** for simulations
- Enables **fast thermal characterization**¹
- Creates initial parameters for **Klippel Controlled Sound (KCS)**

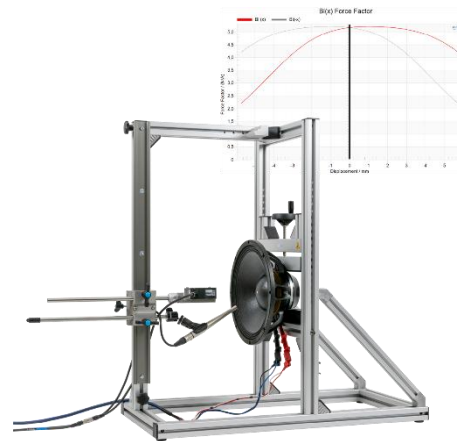

DESCRIPTION

The Fast Large Signal Identification (*FLSI*) software module identifies the elements of the nonlinear lumped parameter model of woofers, micro-speakers, tweeters, and other electrodynamic transducers. The transducer might be mounted in a closed or ported enclosure and operates under normal working conditions. It is excited with a multi-tone signal. Starting in the small-signal domain, the amplitude is gradually increased up to limits admissible for the particular transducer. The maximum amplitude can be determined automatically using the identified transducer parameters and general protection parameters describing the thermal and mechanical load.

The identification of the model parameters is based on the voltage $u(t)$ and current signal $i(t)$, measured at the electrical terminals. The identified model allows locating the root cause of the nonlinear distortion and their contribution to the radiated sound.

FLSI is available in two versions: **FLSI Pro** uses state-of-the art measurement technique comprising the full feature set based on latest research suited for engineers who need deep physical insight, detailed analysis, and a complete set of parameters. **FLSI Standard** uses the identical state-of-the art measurement technique and provides a reduced result data set comparable to that from LPM and LSI3.

Article number FLSI Pro	1000-100
Article number FLSI Standard	1000-200

¹ Only Fast Large Signal Identification Pro

CONTENT

1	Overview	3
2	Requirements	6
3	Limitations	7
4	Output	8
5	References	9
6	Patents	9

1 Overview

1.1 Principle

The transducers considered here have a moving-coil assembly performing an electro-dynamical conversion of the electrical quantities (current and voltage) into mechanical quantities (velocity and force) and vice versa.

Equivalent Circuit

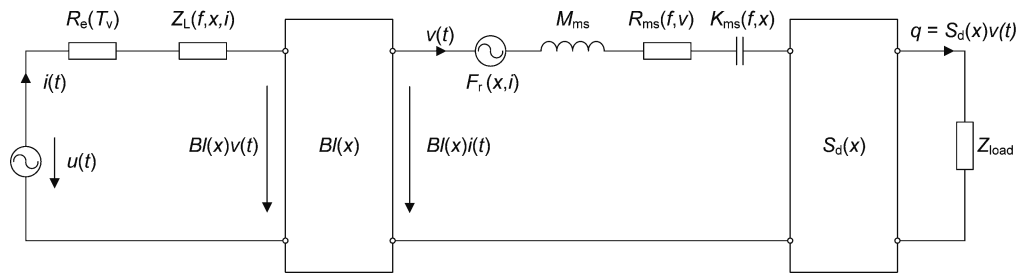

The lumped parameter model describes the large signal behavior of electro-dynamical drivers at high amplitudes. In contrast to the well-known linear model, most elements cannot be assumed to be constant but they depend on one or more speaker states (e.g. displacement x , voice coil velocity v , input current i , voice coil temperature T_v):

- Resistance of the voice coil at DC: $R_e(T_v)$
- Impedance of the voice coil inductance: $Z_L(f, x, i)$,
- Electrodynamical force factor: $Bl(x)$,
- Stiffness of the mechanical suspension: $K_{ms}(f, x)$,
- Mechanical losses: $R_{ms}(f, v)$
- Effective radiation area: $S_d(x)$

The additional impedance Z_{load} , which represents any additional acoustical load such as a resonance caused by a vented enclosure or passive radiator might contain nonlinear parameters as well (see section *Acoustical Load Impedance* below).

Acoustical Load Impedance

The acoustical load has a significant impact on the performance of the loudspeaker system. For instance, a closed box adds a stiffness that has to be compressed when the transducer moves and highly changes the frequency response, efficiency and sensitivity compared to the transducer in free air. The acoustical load can also create additional nonlinear distortion, e.g. due to the nonlinear port resistance in vented speaker systems. Therefore, it is highly recommended to not only perform nonlinear parameter measurements on the transducer, but also on the transducer mounted in the enclosure that shall be used in the final product. In addition to the free air measurement, the following speaker system types are supported by the FLSI. Note that the lumped parameter models shown below are simplified representations. Additional effects identified by FLSI — such as leakage losses and mechanical creep — are included in the parameter estimation but are not explicitly shown in these models.

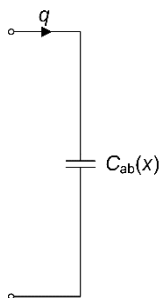

Closed Box:

The loudspeaker cabinet is closed and adds a nonlinear acoustical stiffness $K_{ab}(x) = 1/C_{ab}(x)$ to the transducer's suspension stiffness. $K_{ab}(x)$ is nonlinear because the volume of the air in the cabinet is modulated by the voice coil displacement x .

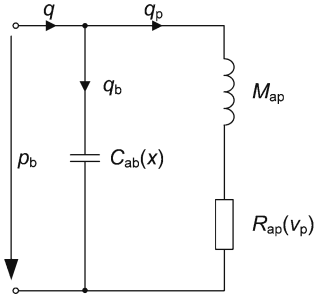
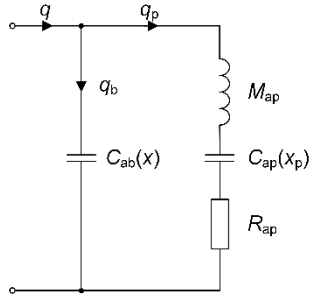
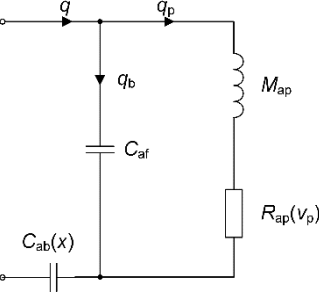
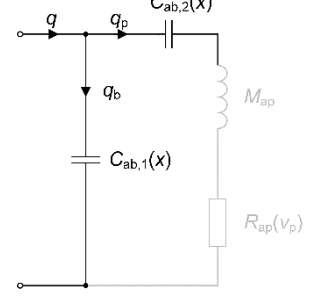
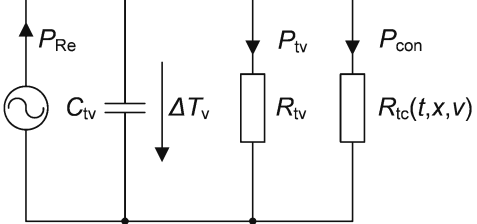
		<p>Vented Box:</p> <p>The vented box uses a port that, together with the compliance of the enclosed $C_{ab}(x)$, creates a Helmholtz resonance. The port is modeled with an acoustic mass M_{ap} and a nonlinear acoustical resistance $R_{ap}(q_p)$, which depends on the volume velocity $q_p = S_p v_p$, with v_p being the mean particle velocity in the port which has an effective opening surface area S_p.</p>
		<p>Passive Radiator System:</p> <p>The passive radiator is a passive element comprising a moving mass, a mechanical suspension and a mechanical resistance. Similarly to the suspension of an electrodynamic transducer, the passive radiator's stiffness $K_{mp}(x_p)$ is nonlinear and depends on the passive radiator displacement x_p.</p>
		<p>4th order Bandpass/Sidefire System:</p> <p>In a fourth order bandpass system, the electrodynamic transducer is mounted in an enclosure with a closed back chamber. A port is located at the front side of the transducer.</p>
		<p>Tweeter:</p> <p>The FLSI module assumes tweeters to be electrodynamic transducers with a closed back chamber. Some tweeters have a small port that separates the back chamber into two. This port may have to be considered in the model to accurately predict the voice coil movement.</p> <p>The FLSI Pro automatically determines whether it considers any port parameters .</p>
<p>Thermal Model²</p>		<p>FLSI identifies a short-term thermal model which equivalent circuit is shown on the left. The model comprises the linear parameters:</p> <ol style="list-style-type: none"> 1. Thermal capacitor C_{tv}: Related to the voice coil mass 2. Thermal resistor R_{tv}: Related to the voice coil surface area <p>In addition, the thermal resistor $R_{tc}(t,x,v)$ describes convection cooling. This effect is represented by the effective thermal bypass factor $\gamma_{con,eff} = P_{con}/P_{Re}$ which ranges between 0% and 100%. A larger bypass factor indicates that a greater portion of the heat is directly transferred to the motor structure and the surrounding environment, rather than contributing to heating of the voice coil.</p>

This model can be used to estimate and compare the power handling capabilities of voice coils (see manual for more information).

1.2 Identification Technique

Principle

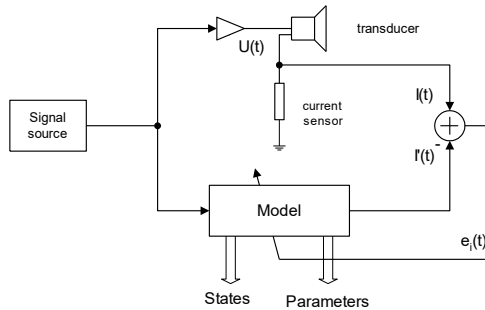

The transducer is excited by a broadband multi-tone signal delivered to the DUT (*device under test*) by a power amplifier. A nonlinear system identification algorithm estimates the voice coil current $i(t)$ which is then compared with the measured current $i(t)$. The amplitude of the difference signal is minimized by adjusting the model parameters adaptively. The output parameters are the optimal linear and nonlinear parameter estimates, the instantaneous state variables (displacement

and statistical values (RMS and peak values).

Supported Speaker Systems

The FLSI measures and identifies the nonlinear lumped parameter model of electrodynamic transducers described above. It is designed for the measurement of individual electrodynamic transducers operated as a single device, i.e., without passive crossovers or multiple drivers connected in series or parallel. The transducer may be mounted in an enclosure as described above (*Acoustical Load Impedance*).

Measuring the transducer in an enclosure similar to the final application, alongside a free-air measurement, is highly recommended to capture the performance characteristics not only of the transducer itself, but of the complete passive system.

Import Parameter

The simplest setup measures the electrical impedance at the transducer terminals and identifies the electrical system in absolute quantities, whereas the mechanical system is identified in relative quantities only. A calibration of the mechanical system is required to calculate the estimated state variables and mechanical parameters in physical units.

The calibration is done by measuring the voice coil excursion using a laser sensor. Comparing the estimated and measured excursion signals, the calibration factor $Bl(x=0)$ can be identified. If a laser is not available or the transducer's membrane is covered, the calibration can be done by importing $Bl(x=0)$, $max(Bl(x))$, the moving mass M_{ms} or by performing an *Added Mass Method*. The calibration using a laser sensor usually gives the most precise result.

Laser

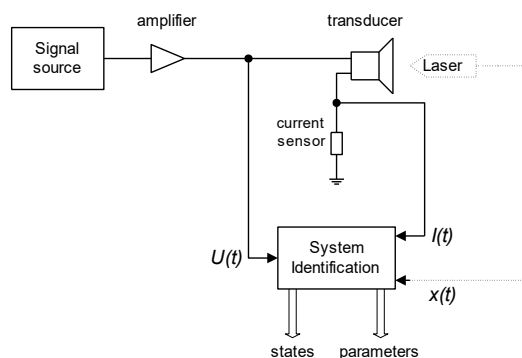

A laser sensor based on triangulation principle (see *A2 Laser Displacement Sensor*) can be used for measuring the voice coil displacement during the test. This information is used for identifying the force factor $Bl(x=0)$. This is required to provide the mechanical parameters in absolute terms.

Microphone

A microphone can optionally be used for measuring impulsive distortion (*Rub&Buzz*)¹. Impulsive distortion metrics are used to identify a reasonable transducer's working range and to prevent mechanical overload.

In addition, the microphone is required to identify the nonlinear distortion caused by $S_d(x)$ ². For the highest precision and to ensure good signal-to-noise-ratio, the distance from the microphone to the transducer's cone should be approximately 1 to 2 times the transducer cone's diameter.

Measurement Procedure	<p>The estimation of the linear and nonlinear parameters consists of a series of steps processed sequentially:</p> <ul style="list-style-type: none"> • LINEAR MODE <ul style="list-style-type: none"> ○ Amplifier check (cables, gain control, limiting) ○ Measurement of resistance R_e close to DC ○ Finding the optimal excitation settings (level, bandwidth, number of averages) for the linear parameter measurement ○ Identification of the linear lumped parameters • ENLARGEMENT MODE (optional) <ul style="list-style-type: none"> ○ Identification of the admissible amplitude • NONLINEAR MODE <ul style="list-style-type: none"> ○ Identification of the nonlinear parameters describing the transducer over its whole working range • THERMAL MODE (optional)² <ul style="list-style-type: none"> ○ Voice coil heating measurement (if required due to insufficient heating in NONLINEAR MODE) ○ Voice coil cooling measurement ○ Identification of Thermal Parameters
Acoustical Environment	<p>The influence of the room acoustics on the driver parameters may be neglected having a normal room size (volume > 30 m³) and keeping a distance of about 1 m to the walls.</p>

1.3 Parameter Identification

Klippel Server	<p>The parameter identification requires an internet connection to identify nonlinear parameter on a Klippel server. The communication with the server happens automatically during the measurement.</p> <p>Measurement Data comprises measurement signals and some setup parameters defined on the property page.</p> <p>Result Data comprises speaker parameters, transfer functions, and modeled transducer states.</p> <div data-bbox="406 1227 1385 1512" data-label="Diagram"> <pre> graph LR subgraph FLSI_MODULE [FLSI MODULE] FLSI_measurement[FLSI measurement] Display_Results[Display Results] end subgraph SERVER [SERVER] Parameter_Identification[Parameter Identification] end Measurement_Data[Measurement Data] Result_Data[Result Data] FLSI_measurement --> Measurement_Data Measurement_Data --> Parameter_Identification Parameter_Identification --> Result_Data Result_Data --> Display_Results </pre> </div> <p>See the privacy policy here for more information about exchanged data.</p>
-----------------------	--

² Only available in Fast Large Signal Identification Pro or with KCS-ID license

2 Requirements

2.1 Hardware	SPEC
---------------------	------

Analyzer		Klippel Analyzer 3 equipped with a <i>Speaker Card</i> and an <i>Amp Card</i> and/or an <i>XLR card</i> .	H3
Amplifier	KA3 Amp-Card or external audio amplifier with a flat frequency response over the desired measurement bandwidth		H6
Microphone	<i>[optional]</i> A microphone with sufficient maximum SPL capabilities to measure the sound pressure in the near-field of the loudspeaker.		A4
Laser Displacement Sensor	<i>[optional]</i> A laser displacement sensor may be used to capture the membrane movement.		A2
Computer	A Windows PC with Internet access is required.		
Klippel Server Access	The parameter identification is performed on a KLIPPEL server. If a firewall is used, it needs to allow outgoing connections to https://klippel.services and its subdomains <a href="https://<SUB_DOMAIN_NAME>.klippel.services">https://<SUB_DOMAIN_NAME>.klippel.services . See the privacy policy here .		

2.2 Software

dB-Lab	Project Management Software of the KLIPPEL R&D SYSTEM. Requires the latest version of dB-Lab 212.
Permissions	The operating system user account running dB-Lab must also have permission to run the program <code>cUrl.exe</code> , which is installed together with dB-Lab.

3 Limitations

3.1 Device Under Test

Parameter	Symbol	Min	Typical	Max	Unit
Voice coil resistance	R_e	1	2-20	300 ³	Ω
Resonance frequency	f_s	15		2000	Hz
Resonance frequency of acoustical resonator	f_b	25		5000	Hz

3.2 Power Amplifier

Parameter	Symbol	Min	Typical	Max	Unit
Frequency response Ref. 1kHz @ 10 Hz ... 10 kHz	$\Delta G_{amp}(f)$	-6	0	+2	dB
Frequency response Ref. 1kHz @ 2 Hz	$\Delta G_{amp}(f_{Re})$	-36	0	+2	dB

3.3 Input Parameters

Parameter	Symbol	Min	Typical	Max	Unit
DRIVER					
Effective area of the driver diaphragm	S_d	0.01		10000	cm ²

Force factor at rest position ¹	$Bl(x=0)$	0.01		1000	N/A
Maximum force factor over the full voice coil excursion range	Bl_{max}	0.01		1000	N/A
Moving mass	M_{ms}	0.0001		10000	g
Box volume	V_b	0.0001		1000	Liter

³ FLSI may work fine with higher resistances, but this cannot be guaranteed and depends on the particular device under test.

4 Output

PARAMETERS AT THE REST POSITION (X=0) IN THE SMALL AND LARGE SIGNAL DOMAIN	
DC resistance	R_e
Linear LR-3 Inductance Parameters	L_e, L_2, R_2, L_3, R_3
Mechanical lumped transducer parameters transformed into the electrical domain	C_{mes}, L_{ces}, R_{es}
Acoustical lumped parameters transformed into the electrical domain	$C_{mep}^1, L_{ceb}^1, R_{ep}^1$
Mechanical transducer parameters ³	$M_{ms}, R_{ms}, K_{ms}, C_{ms}, Bl$
Acoustical lumped parameters transformed into the mechanical domain ³	$M_{mp}^1, R_{mp}^1, K_{mb}^1$
Acoustical lumped parameters (requires S_d Import) ³	M_{ap}^1, R_{ap}^1
Derived transducer parameters	$Q_{ts}, Q_{ms}, Q_{es}, f_s$
Derived transducer parameters based on imported data (S_d, V_b)	V_{as}, η_0, L_m
Vented box/Passive Radiator/Bandpass parameters	Q_b, f_b, α
Closed Box parameters ³	$K_{mt}, C_{mt}, L_{cet}, Q_{tc}, Q_{mc}, Q_{ec}, f_c$
TRANSFER FUNCTIONS	
Measured impedance	$Z(f), \arg(Z(f)),$
Modeled impedances based on small and large signal lumped parameters	$Z_{small}(f), \arg(Z_{small}(f)), Z_{large}(f), \arg(Z_{large}(f)),$
Modeled lossy inductance parameters	$ Z_L(f) , \arg(Z_L(f)), L(f), R_L(f)$
Displacement frequency response magnitudes	Measured and predicted small and large signal frequency responses
Voltage Sensitivity	Modeled voltage sensitivity based on linear parameters in small- and large-signal domain
WAVEFORMS	
Measured time signals	$u(t), i(t), x(t), p(t)^2$
Modeled time signals	$x'(t)$
SPECTRA	
Measured spectra	$U(f), I(f), X(f), P(f)^2$
Modeled spectra	$X(f), P(f)^2$
Modeled distortion components ¹	Total Distortion, Force Factor, Stiffness, External Resistance, Internal Mechanical Damping, Inductance (x), Inductance (i), Reluctance Force, Radiation Area $S_d(x)$, Port
STATES	
Modeling and measurement errors	$E_{lin}, E_{x,lin}, E_{nonlin}, E_{x,nonlin}$
Nonlinear parameter variation	Bl_{min}, C_{min}
Voice coil displacement	$X_{peak}, X_{bottom}, X_{dc}, X_{prot}, X_{rms}, C_x$ (crest factor), K_x (kurtosis)

³ Absolute identification of the mechanical parameters without laser sensor requires import of $Bl(x=0)$ or M_{MS}

Voice coil velocity	v_{rms}
Maximum estimated port velocity	$ v_p _{max}^1$
Electrical signals	$u_{peak}, i_{peak}, u_{rms}, i_{rms}, P_{real}, P_{Re}, P_{mech}, P_{iron}$
Effective distortion components ¹	$D_{total}, D_{bl}, D_k, D_{r,int}, D_{r,ext}, D_{lx}, D_{li}, D_{reduct}, D_{sd}, D_{port}$
NONLINEAR PARAMETERS (CURVES)	
Force factor (Bl -product)	$Bl(x)$
Suspension characteristics	$K_{ms}(x), K_{mt}(x), K_{mb}(x)$
Displacement-dependent impedance magnitude of inductance	$Z_L(f,x)^1, Z_L(f=8.5*fs, x)$
Displacement-dependent Lossy Inductance	$L_l(f,x)$ (contour plot) ¹
Flux Modulation	$\lambda(i)$
Mechanical losses	$R_{ms}(v)^1$
Symmetry Ranges	$Bl(x), K_{ms}(x), K_{mt}(x)$
NONLINEAR PARAMETERS (SINGLE VALUES)	
Maximum Force factor	Bl_{max}
Displacement Limits (IEC 62458)	$x_{Bl}(Bl_{min}), x_c(C_{min}), x_L(Z_{max}), x_d(d_2)$
Minimal parameter ratios	Bl_{min}, C_{min}
Asymmetry metrics	$x_{sym,bl}, x_{sym,k}, a_{bl}, a_{kms}, a_l, a_{rp}^1$
THERMAL PARAMETERS¹	
Thermal resistance of heat transfer from voice coil to pole tips	R_{tv}^1
Thermal capacity of voice coil	C_{tv}^1
Thermal time constant	τ_v^1
Bypass factor (convection cooling)	$\gamma_{con,eff}^1$
EXPORT	
Graphics to Clipboard	
Parameters for Simulation	

5 References

5.1 Related Modules	[S3] SIM2 [S2] LPM – Linear Parameter Measurement [S52] LSI3 Large Signal Identification [S66] KCS-ID
5.2 Manuals	https://www.klippel.de/go/manuals#kl-fastlsi

6 Patents

Germany	102007005070, 1020120202717, 102014005381.4, 19714199, 4111884.7, 4336608.2, 43340407, 4332804.0, 102013012811, 102013021599.4, 102013000684, 102009033614, 102009033614, P10214407
USA	8,078,433; 14/436,222; 14/683,351; 6,058,195; 5,438,625; 6005952; 5,577,126; 5815585; 5,528,695; 14/499,379; 577,604; 8,964,996; 14/152,556; 12/819,455; 12/819,455; 7,221,167
China	ZL200810092055.4; 201380054458.9; 201510172626.5; 981062849; 2014103769646; 2014107954970; 2014100795121; 201010228820.8; 201010228820.8; 03108708.6
Japan	5364271; 2972708
Europe	13786635.6; 0508392A2
Taiwan	102137485
India	844/MUMNP/2015

GB	2324888
Hong Kong	1020403
Korea	1020140095591

Find explanations for symbols at:

<http://www.klippel.de/know-how/literature.html>

Last updated: May 19, 2026

Designs and specifications are subject to change without notice due to modifications or improvements.

